

# SERIE SMART

Rollers diam. 50 mm

Std smooth belt in PU  
colour P320, with  
slats h 20 mm pitch  
40 mm

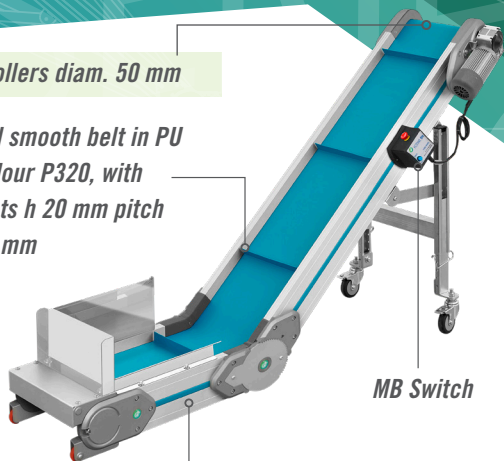

MB Switch

Structure in ALU profile h 120 mm  
with integrated side edges h 35

Transmission group  
0,09 kW R=1:50  
Std speed 4,5 m/min

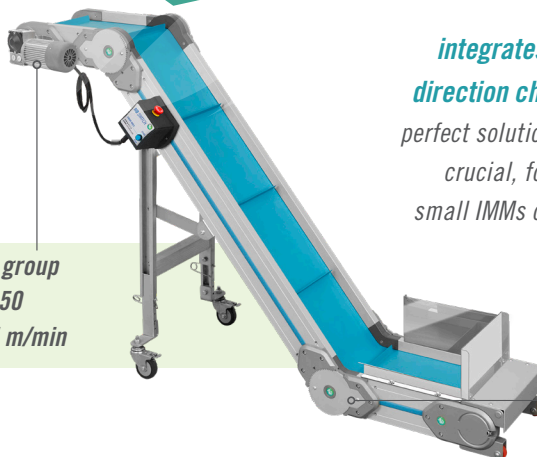

**Smart Line**  
integrates MB's conveyors with  
**direction change range**, offering a  
perfect solution when compact size is  
crucial, for example working with  
small IMM or other small machines

Adjustable direction-  
change housings with  
toothed aluminum insert

## + DIMENSIONS

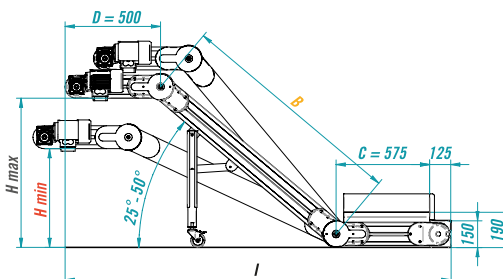
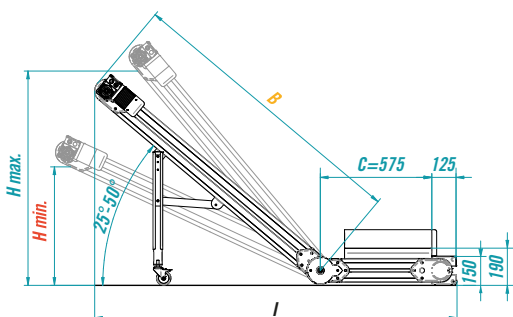

→ IMM: 40/80 ton.

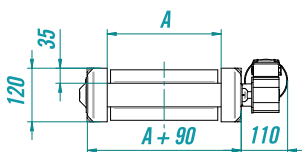

## QUICK CONVEYOR SELECTION GUIDE

### SMART

IMMs up to 40/80ton

Useful width up to  
355mm x length max  
 $B+C(+D)= 3000$  mm

Std slats h 20 mm  
- h max 30 mm

Spondaflex:  
**NOT POSSIBLE**

High-grip belt:  
POSSIBLE

PC covers:  
POSSIBLE without structure

### N-

IMMs 80 t to 250 t

Useful width up to 540  
mm x length max  
 $B+C(+D)= 6000$  mm

Std slats h 35 mm  
- h max 50 mm

Spondaflex h 30 mm  
slats h 20 mm

Special optionals not  
suitable for SMART SERIES  
(PC covers with structure,  
cooling systems, separators  
SRS / FSRV, N-DUCK ...)

### CP2021

IMMs from 250 t to 500 t, PET

Bigger size / heavy duty,  
possible with special drive  
roller diam 80-120mm

Slats h up to 80 mm

Spondaflex h 50 mm  
slats h 30 mm

Special optionals not suitable  
for SMART and N - SERIES  
(internal side protections,  
special belts ...)

Inclination >50° (fixed)

## + STRENGTHS:

- Lightweight structure and compact size
- Reduced consumption: 0,09 kW
- Low cost

Contact us to get a  
customized quotation!