

ZERMA

THE HOME OF SIZE REDUCTION

Shredders // **Granulators** // Pulverizers // Accessories

GSL // GSE // GSC // GSH // GSP // ZHM

GSL 300 BESIDE THE PRESS GRANULATOR

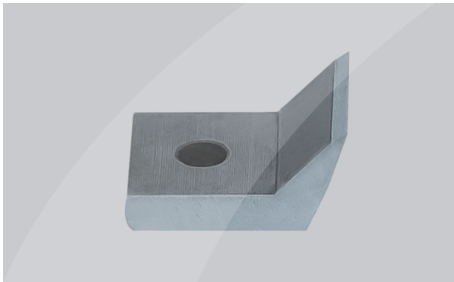

The curvature of the specially profiled rotor knives ensures a constant cutting radius after re-sharpening thus maintaining the original cutting gap. Awkward knife adjustment is no longer necessary.

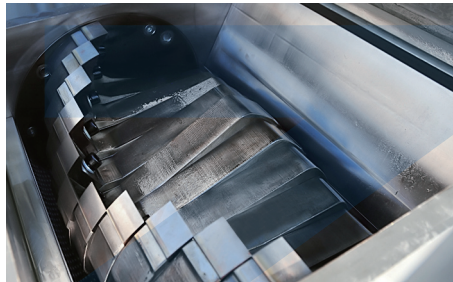

Staggered rotor blades create an individual blade cut thus increasing the cutting torque. All of the machines in this series are therefore suitable for grinding more solid materials and thicker walled sprues.



Due to the Quick snap fasteners used on the GSL series machines, the machines can be opened for cleaning and maintenance quickly without the need for special tools.

GENERAL DESCRIPTION

The slow speed granulators in the GSL 300 range feature a staggered 300 mm diameter rotor with widths ranging from 400 to 800 mm. The rotor is directly driven by a geared motor. The low rotor speed reduces the noise level of the machine and creates less dust while grinding. The special design knives of the GSL series can be sharpened easily and do not need adjustment afterwards. The material is fed via a sound absorbing feed hopper that can be tailored to fit various applications and feeding ways. Depending on the requirements the machines can be fitted with a wide variety of hoppers, they are mounted on either low or high level base frames with matching suction bins or bag filling adapters. Quick snap fasteners and hand screws make access to the machine for cleaning and maintenance fast and easy.

APPLICATIONS

The GSL slow speed granulators of the 300 series are mainly used in injection and blow molding processes as beside the press machines to grind runners and sprues. But they can be used as low noise central granulators for small throughput requirements as well. The stronger design of the 300 series GSLs allow them to be used for stronger and thicker materials while offering the same advantages regarding low noise and dust as the smaller GSL machines. All GSL models can be equipped with a built in blower system in case a vacuum loading system is not available, or to transport the ground material to bags for storage.

ADVANTAGES

- **Direct driven staggered rotor**
- **Special knife design makes adjustment unnecessary**
- **Easy access for maintenance and cleaning**
- **Slow rotor speed creates less noise and dust**
- **Easily customizable to suit different applications**

ENGLISH

PLASTIC SIZE REDUCTION
RUBBER SIZE REDUCTION
WOOD SIZE REDUCTION
E-WASTE SIZE REDUCTION



ZERMA

GSL BESIDE THE PRESS GRANULATOR



PLASTIC
SIZE
REDUCTION

ZERMA. THE
HOME OF SIZE
REDUCTION



SPECIFICATIONS

Type GSL	300/400	300/600	300/800
Rotor diameter (mm)	300	300	300
Rotor width (mm)	400	600	800
Rotor speed (rpm)	150	150	150
Drive capacity (kW)	7.5	11	18.5
Rotor knives (pcs)	33	48	66
Stator blades (rows)	2	2	2
Screen size (mm)	>5	>5	>5
A (mm)	1125	1125	1135
B (mm)	400	400	400
C (mm)	1335	1335	1340
D (mm)	405	600	830
E (mm)	1035	1230	1635

DIMENSIONS

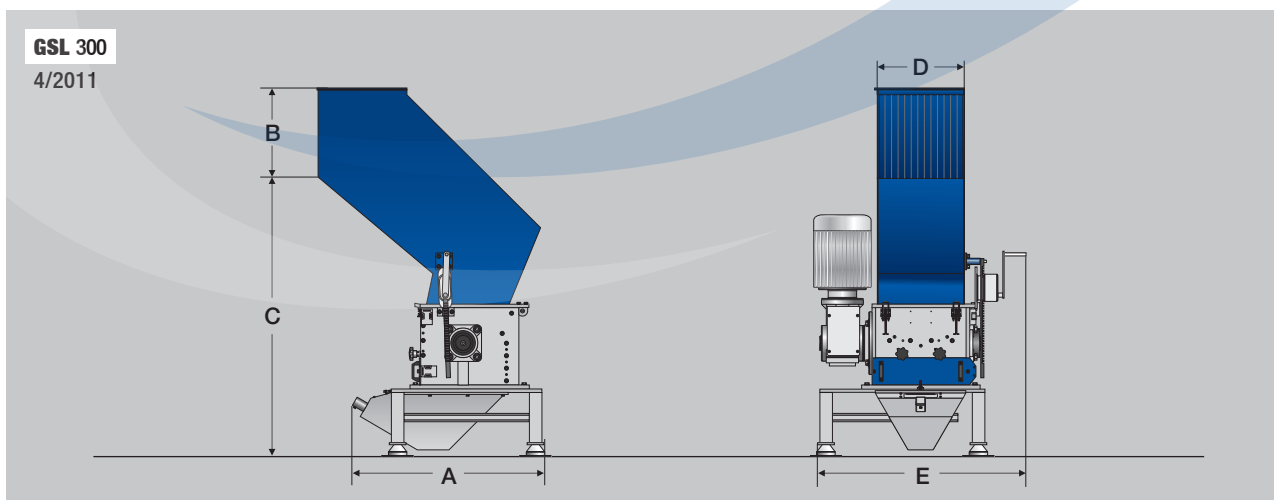

TAME PARK | TAMWORTH | STAFFORDSHIRE | B77 5DY
ENGLAND
PHONE : +44 (0) 1827 265 800 FAX : +44 (0) 1827 265 801
E-MAIL : INFO@SUMMITSYSTEMS.CO.UK

ZERMA UK
POWERED BY SUMMIT SYSTEMS LTD.

WWW.ZERMA.COM

Subject to technical modification